

DIMENSIONI D'INGOMBRO - OVER ALL DIMENSIONS

(MACCHINE MONTATE) - (MACHINES ASSEMBLED)

Modelli-Models	(A) mm	(B) mm	(B1) mm con incisore with scoring	(C) mm	(C1) mm con incisore with scoring	(D) mm	(E) mm	(F) mm	(F1) mm con incisore with scoring	(G) mm	(H) mm	Peso Netto Net Weight kg
KGS 125 BRICO	3500	1960	/	1800	/	800	1300	1920	-	600	950	240
KGS 185 BRICO	4200	2560	/	2400	/	800	1300	2520	-	600	950	275
KGS 220 BRICO	5200	2910	/	2750	/	800	1300	2870	-	600	950	310
KGS 4SE	4900	2820	2820	2350	2350	800	1500	2800	2800	700	850	580
KGS 300	4300	2580	2580	2100	2100	800	1500	2550	2550	700	850	590
KGS 400	5300	2820	2820	2350	2350	800	1500	2800	2800	700	850	688
KGS 32-19	4300	2580	2580	2100	2100	800	1500	2550	2550	750	950	710
KGS 42-22	5300	2820	2820	2350	2350	800	1500	2800	2800	750	950	808
KGS 42-22 A	5300	2920	2920	2350	2350	800	1500	2900	2900	750	950	908
KGS 510 S	5300	2790	2790	2470	2470	900	1600	2650	2750	800	1050	780
KGS 515 S	5300	2960	3060	2720	2720	900	1600	2920	3020	800	1050	890
KGS 610 S	6300	2960	3060	2720	2720	900	1600	2920	3020	800	1050	1050
KGS 630 S	6300	3150	3150	2720	2720	900	1600	3010	3110	900	1100	1200
KGS 660 S	6300	3150	3150	2720	2720	900	1600	3010	3110	900	1100	1250
KGS 660S EM6	6300	3150	3150	2720	2720	900	1600	3010	3110	900	1100	1250
KGS 700 ES	6300	3150	3150	2720	2720	900	1600	3010	3110	1050	1100	1400

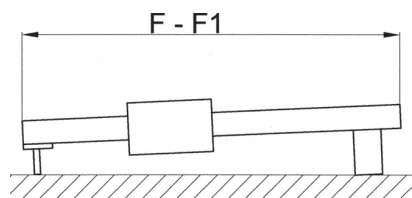

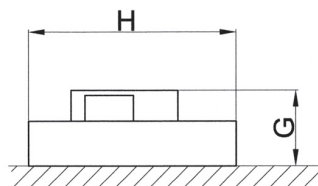
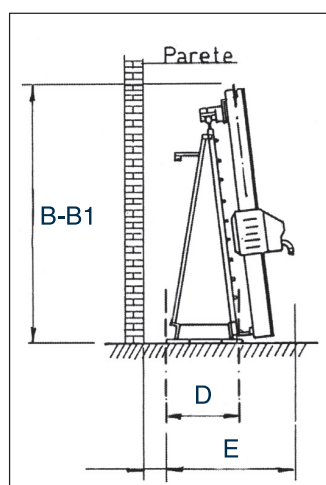
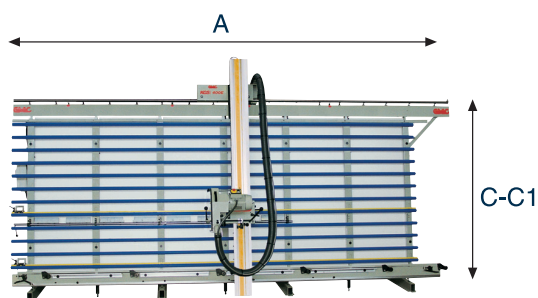
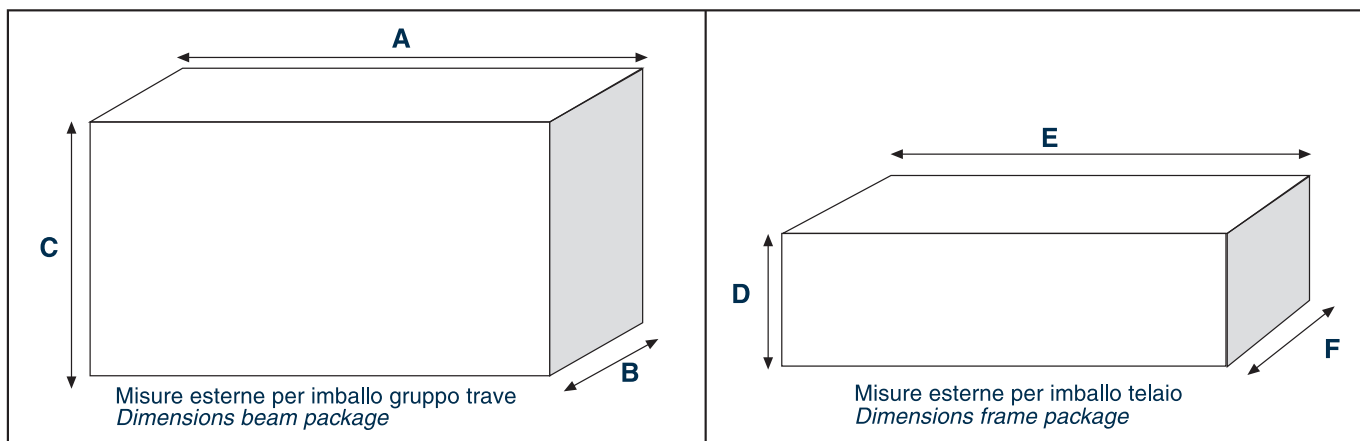

Modelli-Models	A mm	B mm	C mm	Peso Netto Kg Net Weight	Lordo Gabbia Kg Gross Weight Crate	Lordo Cassa Kg Gross Weight Case	D mm	E mm	F mm	Peso Netto Kg Net Weight	Lordo Gabbia Kg Gross Weight Crate	Lordo Cassa Kg Gross Weight Case
KGS 125 BRICO	2120	1050	750	80	100	120	450	3720	900	160	190	220
KGS 185 BRICO	2720	1050	750	85	105	125	450	4420	900	190	220	260
KGS 220 BRICO	3070	1050	750	90	110	130	450	5420	900	220	250	300
KGS 4SE	2900	930	850	268	334	398	2270	5020	350	312	412	542
KGS 300 E	2650	930	850	250	310	370	1050	4420	350	340	415	620
KGS 400 E	2900	930	850	268	334	398	2270	5420	350	420	516	710
KGS 32-19	2650	1050	900	320	350	440	2050	4420	350	390	490	670
KGS 42-22	2900	1050	900	380	450	520	2270	5420	350	428	524	718
KGS 42-22 A	3000	1050	1000	460	520	610	2270	5420	350	448	544	738
KGS 510 S	2800	1170	950	380	462	540	600	5450	1050	400	534	610
KGS 515 S	3050	1170	950	385	470	565	600	5450	1050	505	640	725
KGS 610 S	3050	1170	950	385	470	565	600	6450	1050	665	810	965
KGS 630 S	3150	1200	1050	585	680	765	600	6450	1050	665	810	965
KGS 660 S	3150	1200	1050	625	720	805	600	6450	1050	665	810	965
KGS 660S EM6	3150	1200	1050	625	720	805	600	6450	1050	665	810	965
KGS 700 ES	3150	1200	1200	735	830	935	600	6450	1050	665	810	965